

Vibratory Hammer Specifications

ECCENTRIC MOMENT	5,000	IN-LBS
DYNAMIC FORCE	182	TONS
FREQUENCY, MAINTAINED	1,600	VPM
AMPLITUDE	1.125	IN
MAX. RATED LINE PULL	60	TONS*
HOSE BUNDLE LENGTH	160	FT
SUSPENDED WEIGHT	18,000	LBS
EXCITER WEIGHT WITHOUT CLAMP	14,200	LBS
TRANSPORT WEIGHT W/ 200T CLAMP AND SHIPPING STAND	21,900	LBS
SHIPPING DIMENSIONS - L X W X H	120 x 76 x 108	IN
200T CLAMP WEIGHT	2,800	LBS
125T CAISSON CLAMP WEIGHT	1,800	LBS (EACH)
HD CAISSON BEAM WEIGHT	580	LBS (PER FT)

*75 TON - MAX RATED LINE PULL OPTION AVAILABLE

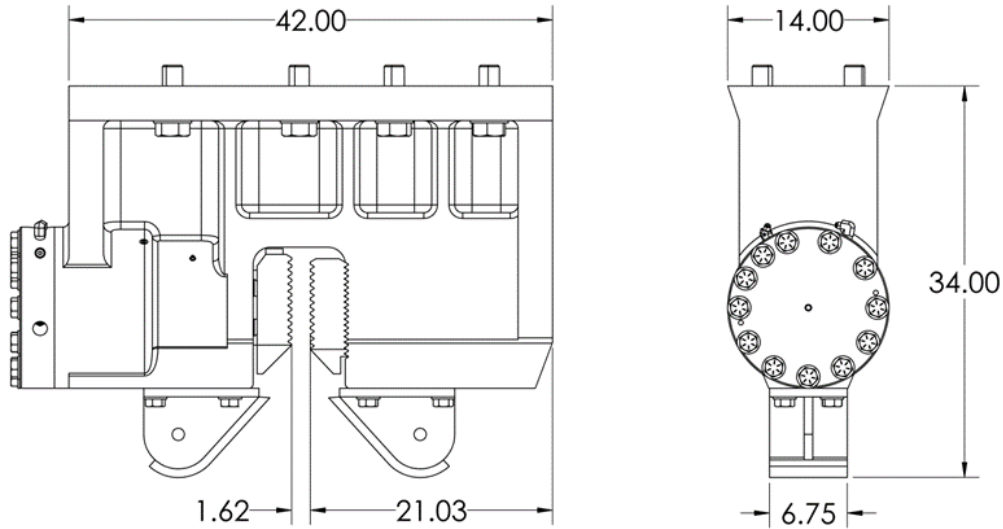

200 Ton Clamp Specifications

Clamp Style	UNIVERSAL CLAMP
Clamping Force	200 TONS
Max Jaw Opening	1.62 IN
200T Clamp Weight	2,800 LBS

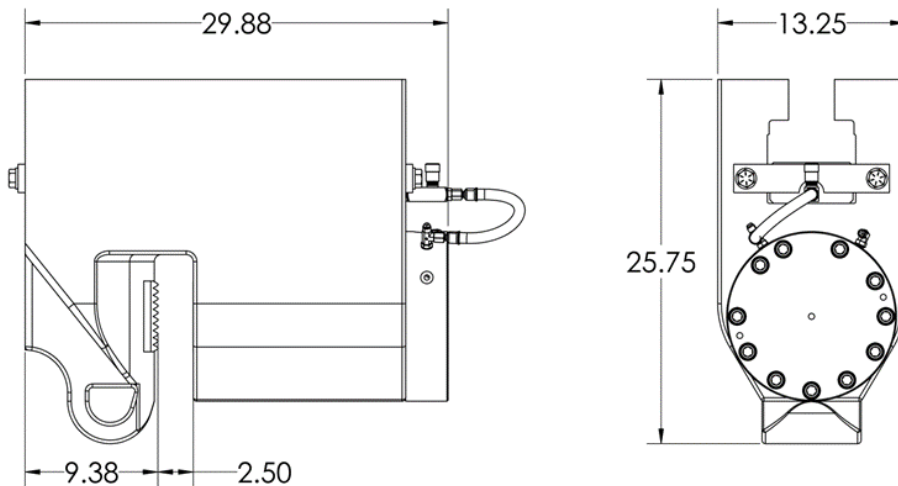

125 Ton Clamp Specifications

CLAMP STYLE	CAISSON CLAMP
CLAMPING FORCE	125 TONS
MAX JAW OPENING	2.50 IN
125T CLAMP WEIGHT	1,800 LBS
CAISSON BEAM WEIGHT	580 LBS (PER FT)

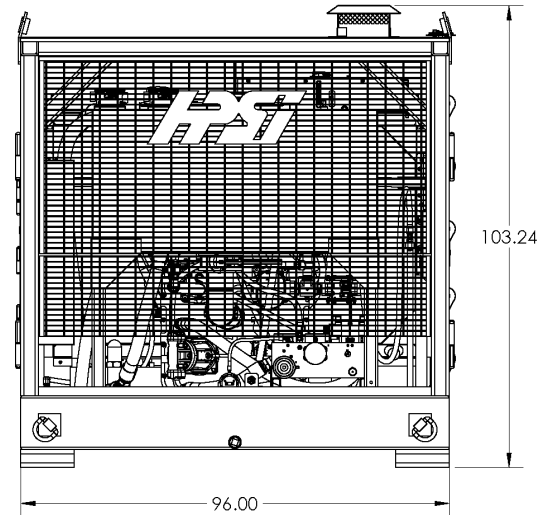
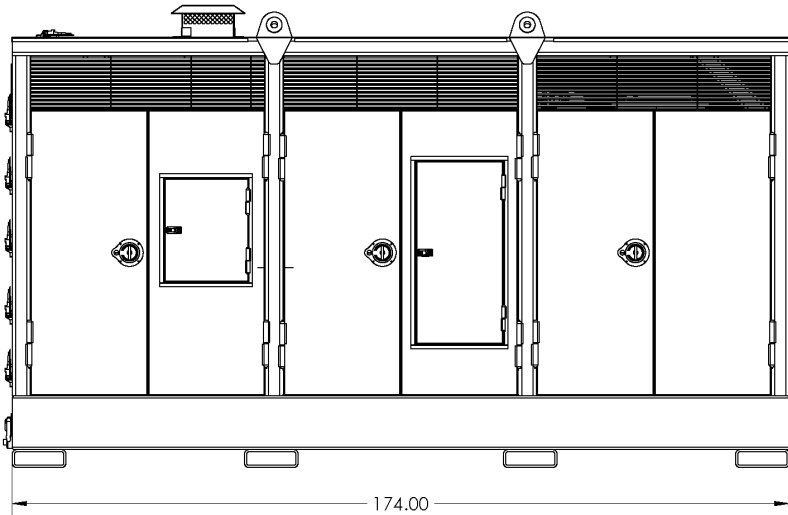

500 Power Pack Specifications

ENGINE	CATERPILLER C18
EMISSIONS TIER	TIER 4 FINAL- NO DEF
RATED POWER	755 HP
SPEED	2,100 RPM
HYDRAULIC FLOW	202 GPM
HYDRAULIC DRIVE PRESSURE	5,000 PSI
HYDRAULIC OIL CAPACITY	400 GAL
DIESEL FUEL CAPACITY	180 GAL
REMOTE CONTROL PENDANT	50 FT
WEIGHT	23,600 LBS